

REV.	ECN NO.	DESCRIPTION	DRA	DATE

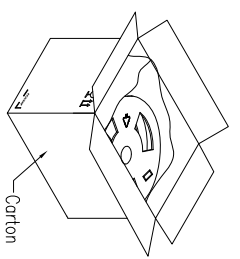

- NOTE:
1. MATERIAL: BLACK PS
 2. PEELING SPEED: 300mm/MINUTE
剥离力: 30gf~90gf, 剥离角度: 155°~180°
 3. CARTON:

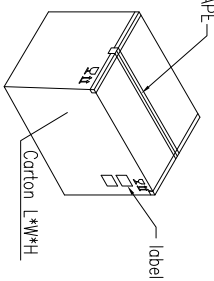
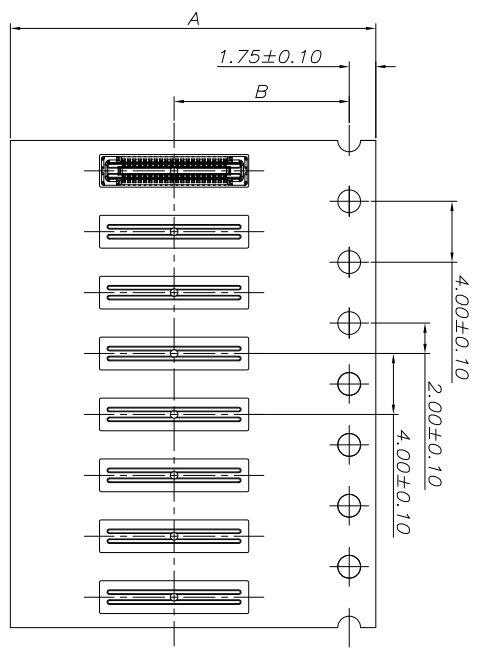
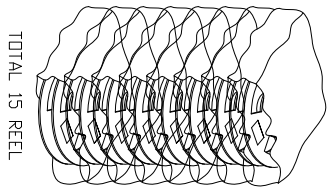
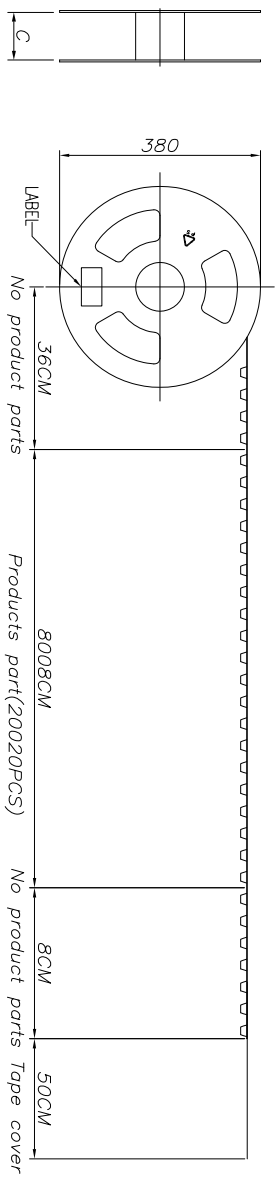
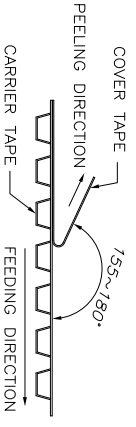

- PACKING:
- 1) OK-118KF030/2-35
20000PCS/REEL
15REEL/BOX
300000PCS/BOX
 - 2) OK-118KF0XX/2-35
20000PCS/REEL
10REEL/BOX
200000PCS/BOX

ONLY FOR ORBBEC

10	24	30	34	38	40	50
16.0	7.5	17.4	24.0	11.5	25.4	
A	B	C				

DIMENSION IN mm	
TOLERANCE UNLESS OTHERWISE SPECIFIED	
DIMENSION	ANGLES
.0 ±0.20	±2°
.0 ±0.10	±1°
.00 ±0.05	.00±0.5°
.000±0.01	.000±0.3°

OCN 奇科技
OCN TECHNOLOGY

APPD: TITLE: 0.35MM BFB 0.7H CONNECTORS SOCKET

CHKD: DWG NO: OK-118RR**/2-35

DRA: PROJ: SIZE: A4 SHEET: 2/2 SCALE: 1:1 REV: A0

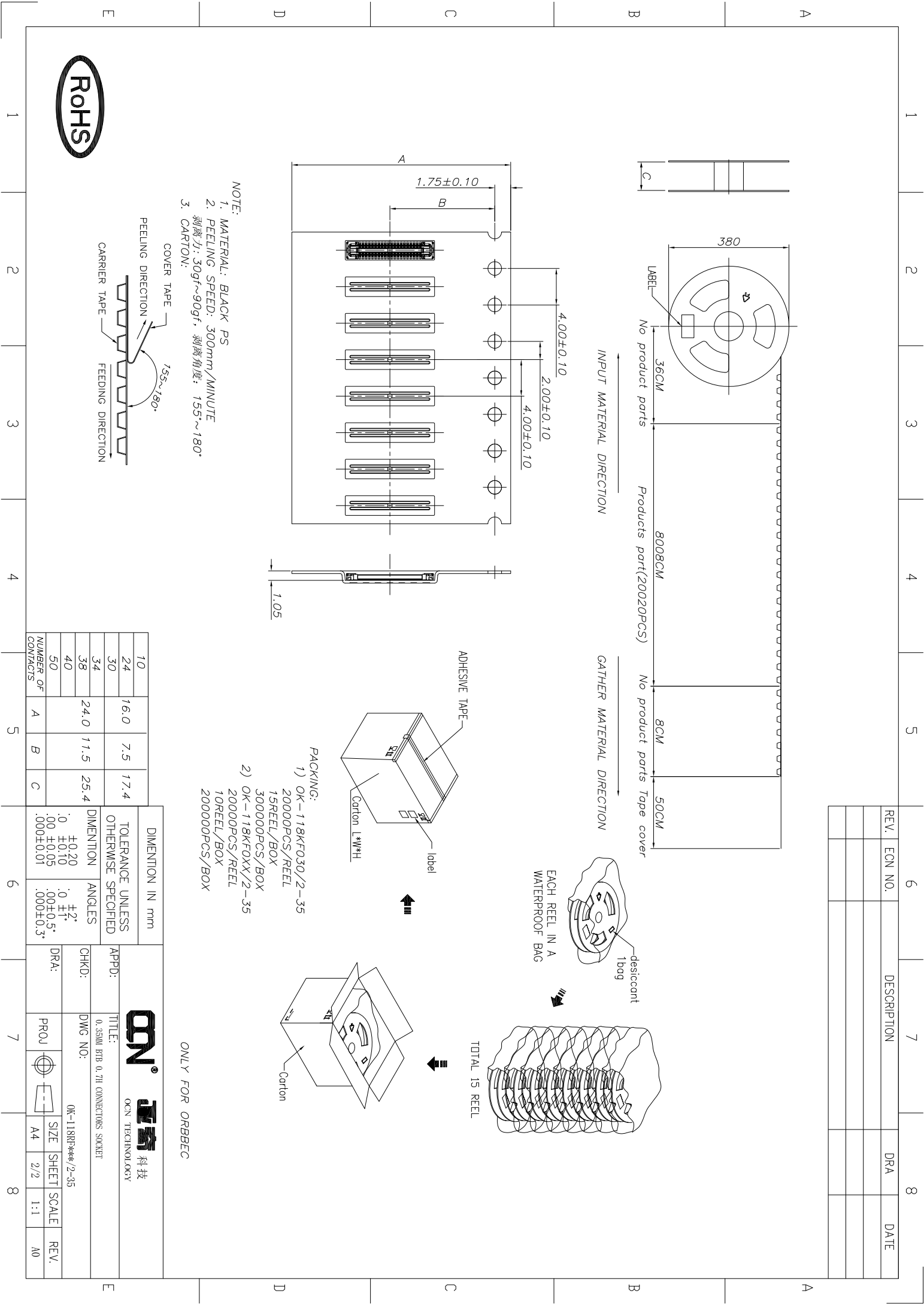

REV.	ECN NO.	DESCRIPTION	DRA	DATE

SPECIFICATIONS:

- MATERIAL:**
1-1 MOLDED PORTION: LCP (UL94 V-0)
1-2 CONTACT AND POST: COPPER ALLOY
- SURFACE TREATMENT:**
TERMINAL PORTION: BASE: NICKEL PLATING ALL OVER;
GOLD PLATING CONTACT : AU PLATING ALL OVER;
SOLDER AREA : AU PLATING ALL OVER
- CHARACTERISTICS:**
3-1. RATED VOLTAGE: 50V AC/DC
3-2. RATED CURRENT: POWER PIN 3A/CONTACTO;
3-3. SIGNAL PIN 0.3A/CONTACT (MAX. 5A AT TOTAL CONTACT)
3-4. INSULATION RESISTANCE: MIN. 1000MΩ (INITIAL)
3-5. BREAKDOWN VOLTAGE: 250V AC FOR 1 MIN.
3-6. SALTWATER SPRAY RESISTANCE (HEADER AND SOCKET MATED):
48 HOURS, INSULATION RESISTANCE MIN. 1000MΩ,
CONTACT RESISTANCE 420mΩ
3-7. CONTACT RESISTANCE: POWER PIN 20mΩ MAX;
SIGNAL PIN 50mΩ MAX
3-8. AMBIENT TEMPERATURE: -55°C ~ +85°C (PRODUCT ONLY);
-40°C ~ +50°C (EMBOSS PACKING)
3-9. STORAGE TEMPERATURE: -55°C ~ +85°C
3-10. WARRANTY PERIOD: 12 MONTH
3-11. COMPOSITE INSERTION FORCE: 1.5N/PIN MAX (40N MAX TOTAL)
3-12. COMPOSITE REMOVAL FORCE: 0.15N/PIN MIN.
3-12. DURABILITY: 30 TIMES

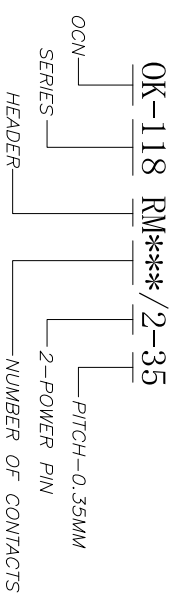
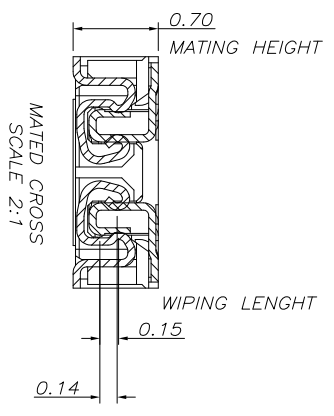
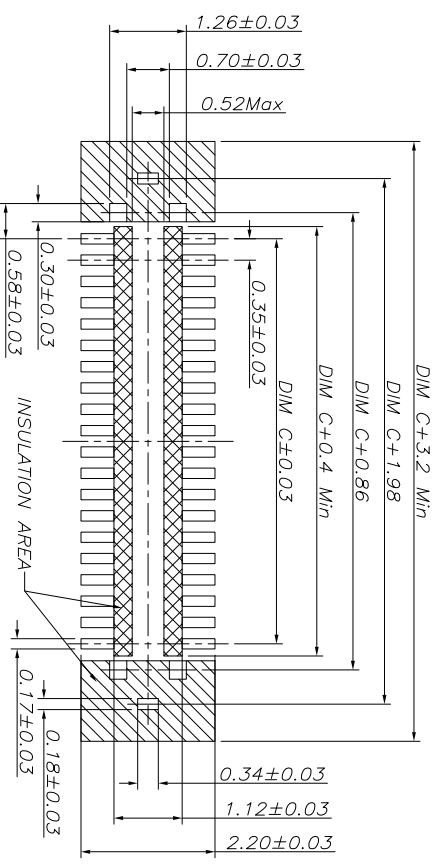
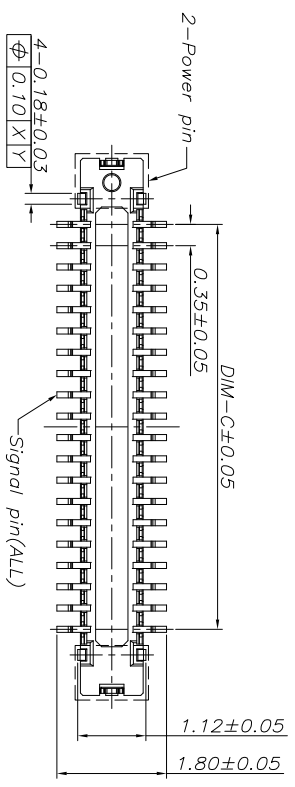
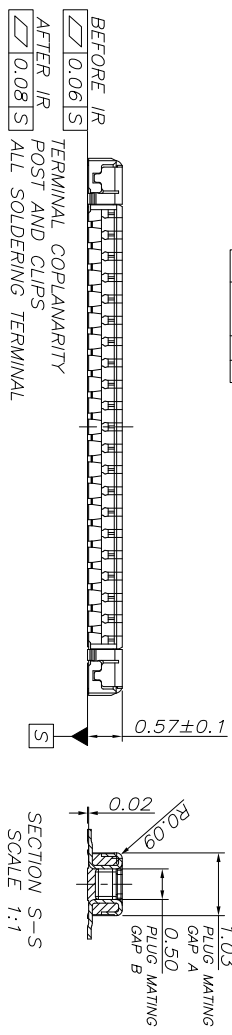
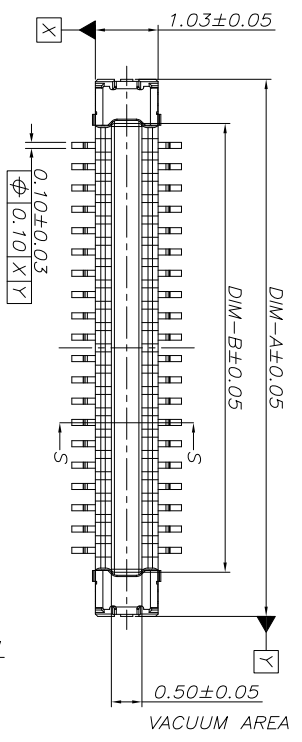

NUMBER OF CONTACTS	DIM A	DIM B	DIM C
10	3.57	2.12	1.40
24	6.02	4.57	3.85
30	7.07	5.62	4.90
34	7.77	6.32	5.60
38	8.47	7.02	6.30
40	8.82	7.37	6.65
50	10.57	9.12	8.40



DIMENSION IN mm		TOLERANCE UNLESS OTHERWISE SPECIFIED	
DIMENSION	±0.20	ANGLES	±2°
	±0.10		±1°
	±0.05		±0.5°
	±0.01		±0.3°

APPD:	TITLE:	OCN 奇科技
CHKD:	DWG NO.:	OK-118RM***/2-35
DRA:	PROJ:	SIZE SHEET SCALE REV.
		A4 1/2 1:1 A0

1 2 3 4 5 6 7 8

REV.	ECN NO.	DESCRIPTION	DRA	DATE

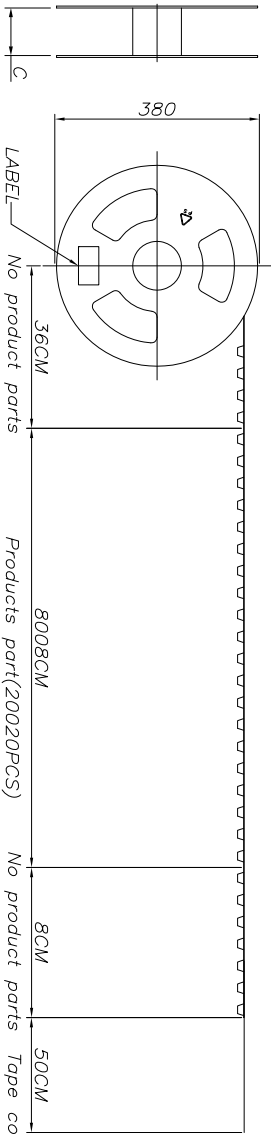

INPUT MATERIAL DIRECTION

GATHER MATERIAL DIRECTION

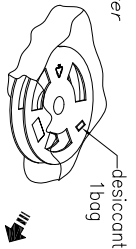

EACH REEL IN A WATERPROOF BAG

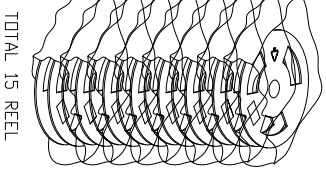

TOTAL 15 REEL

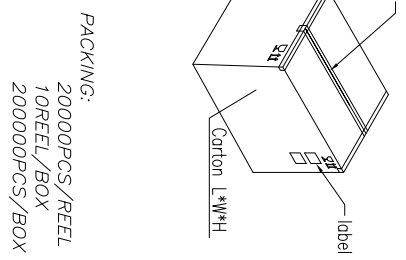
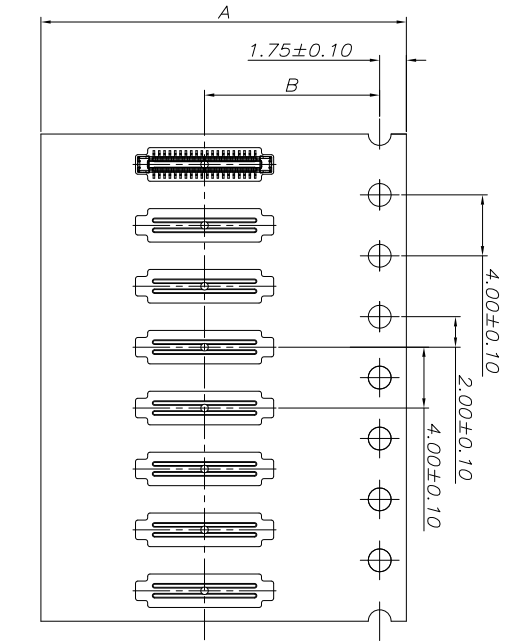

PACKING:
20000PCS/REEL
10REEL/BOX
200000PCS/BOX

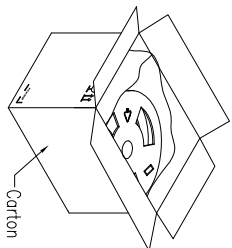

- NOTE:
1. MATERIAL: BLACK PS
 2. PEELING SPEED: 300mm/MINUTE
剥離力: 30gf~90gf, 剥離角度: 155°~180°
 3. CARTON:

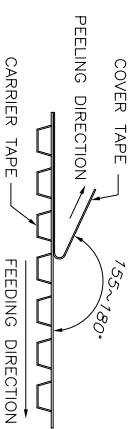

	A	B	C
10	16.0	7.5	17.4
24			
30			
34			
38	24.0	11.5	25.4
40			
50			
NUMBER OF CONTACTS	A	B	C

DIMENSION	IN mm
TOLERANCE UNLESS OTHERWISE SPECIFIED	
DIMENSION	ANGLES
.0	±.2°
±0.10	0 ±1°
.00 ±0.05	.00±0.5°
.000±0.01	.000±0.3°

OCN 科技
OCN TECHNOLOGY

APPD: TITLE: 0.35MM BTB 0.7H CONNECTORS HEADER
CHKD: DWG NO: OK-118RM**/2-35

DRA: PROJ: SIZE: A4 SHEET: 2/2 SCALE: 1:1 REV: A0

